

# FOS550 / PV550



⚠️ Mögliche Sachschäden  
⚠️ Dégâts matériels possibles  
⚠️ Mogelijk materiële schade  
⚠️ Possibili danni materiali  
⚠️ Potential damage to property



ℹ️ Hinweise zur Montage  
ℹ️ Instructions de montage  
ℹ️ Instructies voor de montage  
ℹ️ Note per l'installazione  
ℹ️ Further fitting details



Toepassing RC2 / 3 minuten Hout: Zie instructie Kunststof met staal versterking: Zie instructie Kunststof zonder staal versterking: Met BA anker of IM100 chemisch anker Metaal: Zie instructie	Toepassing RC3 / 5 minuten Altijd met BA anker
---	---

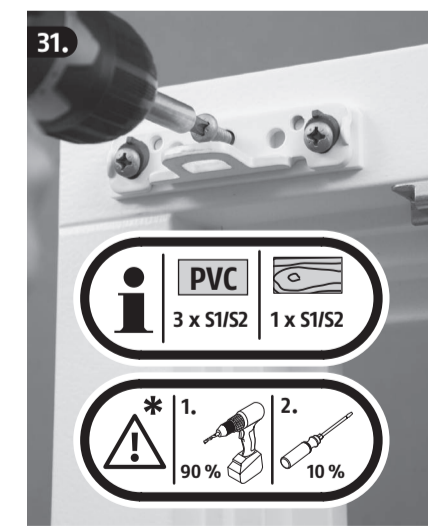
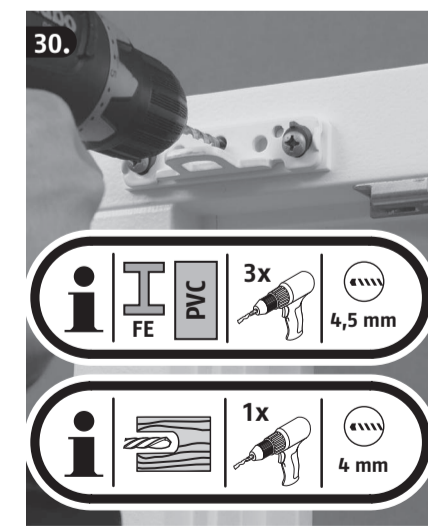
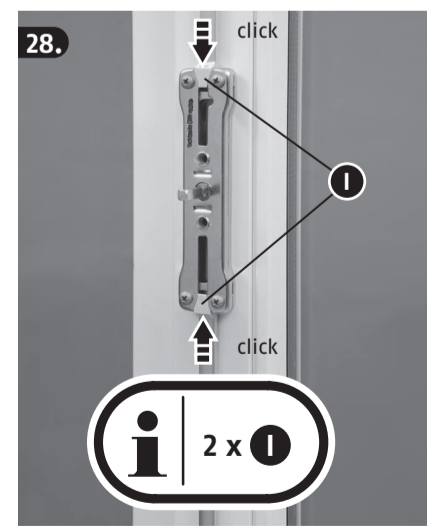
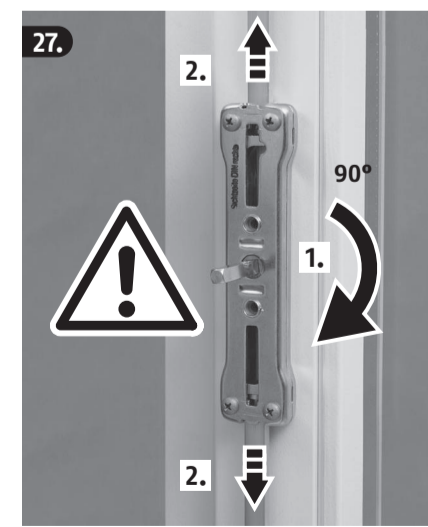
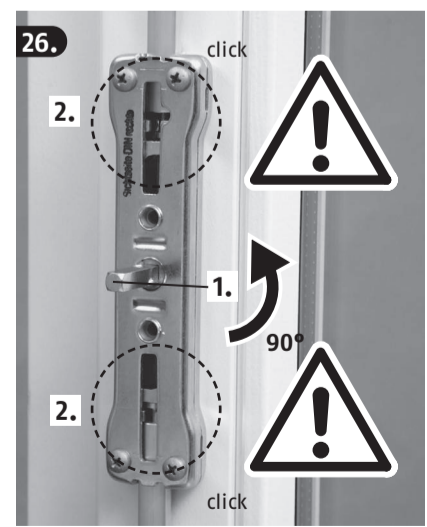
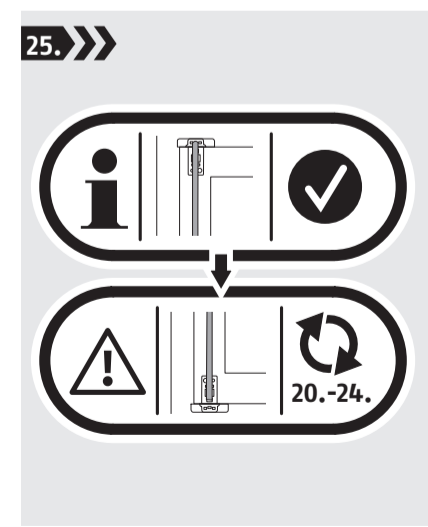
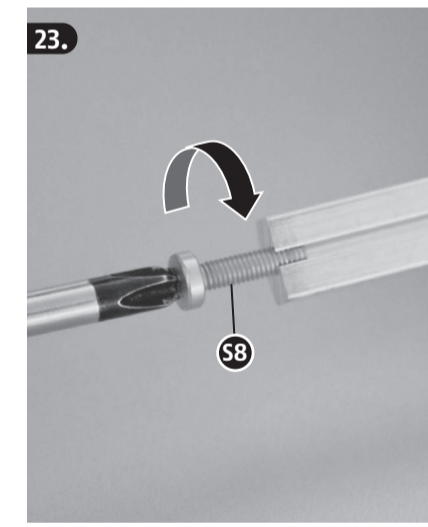
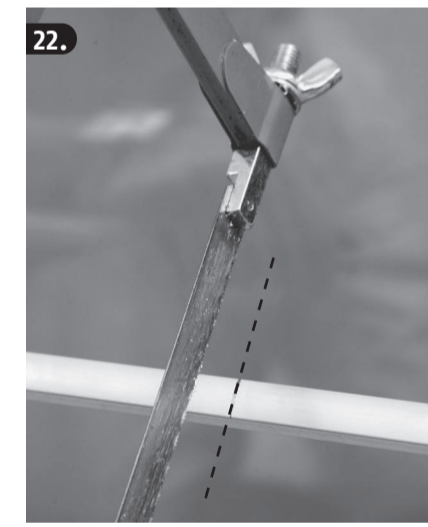
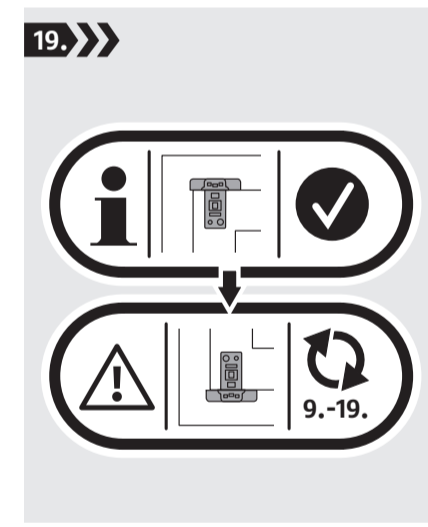
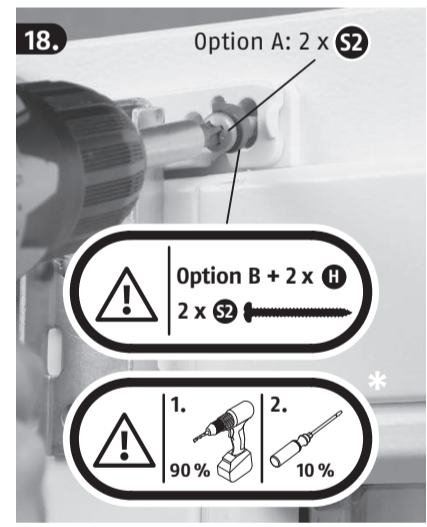
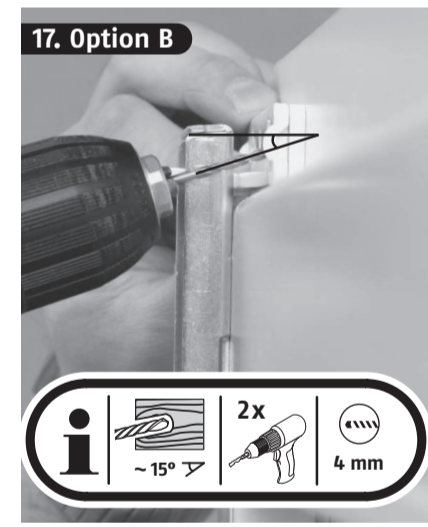
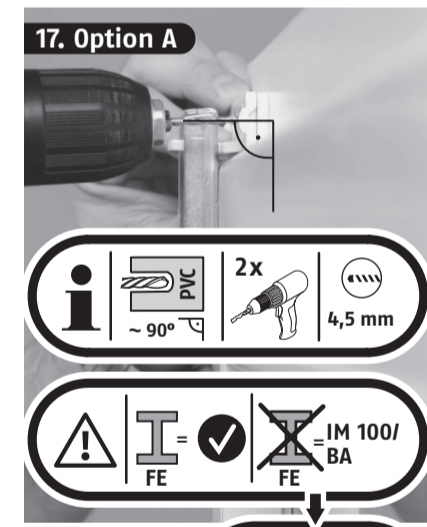
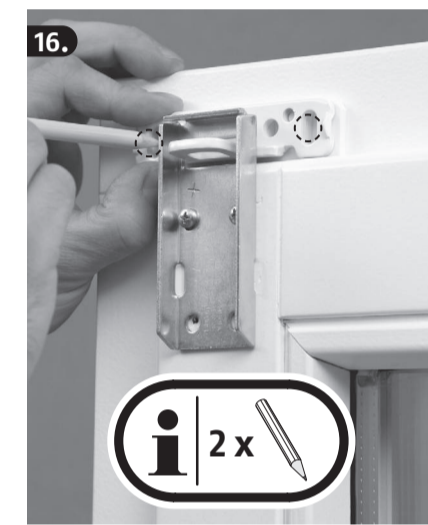
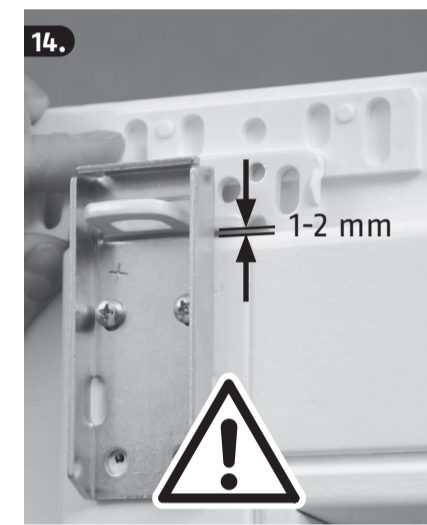
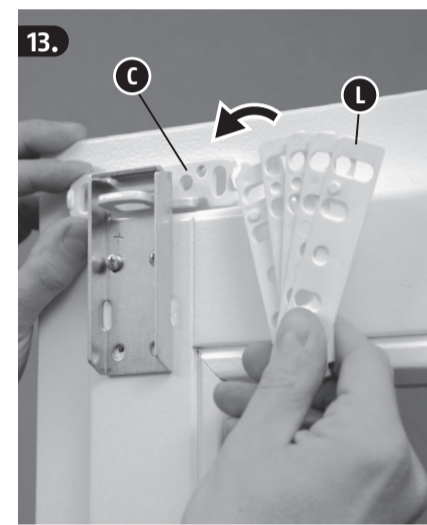
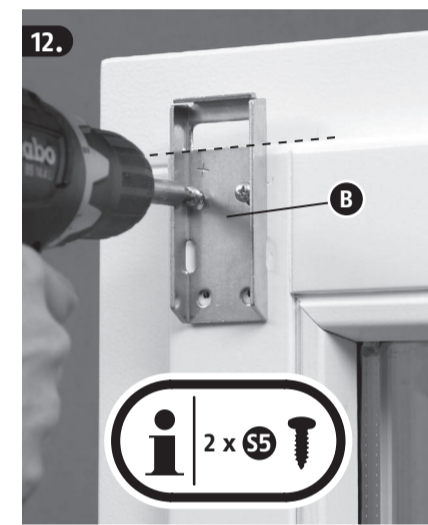
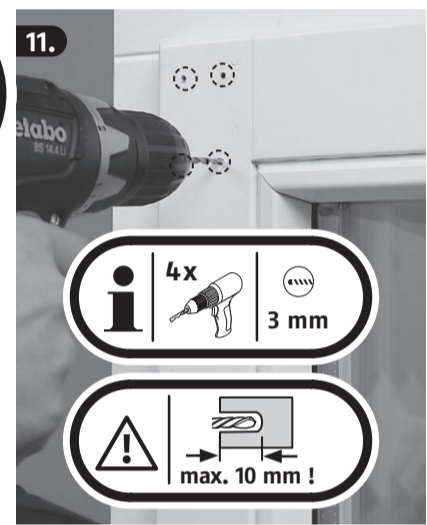
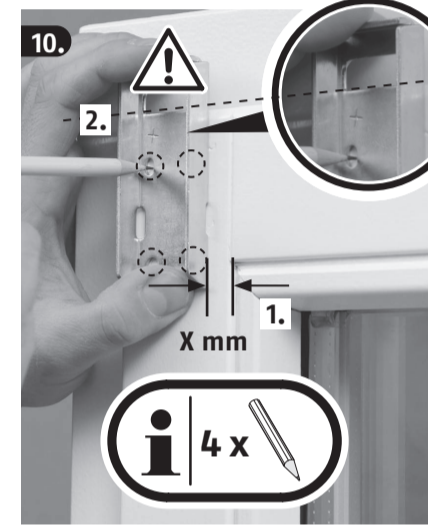
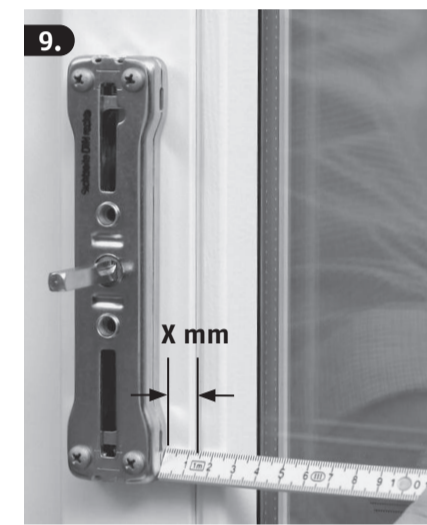
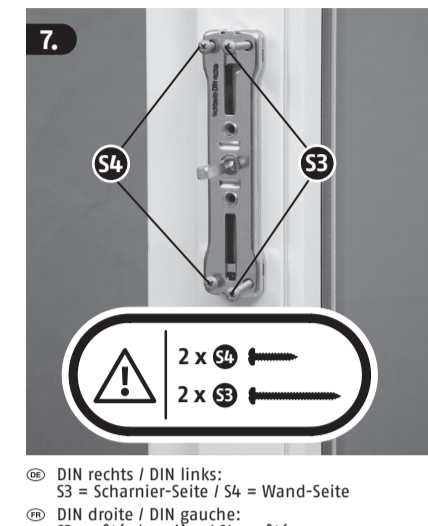
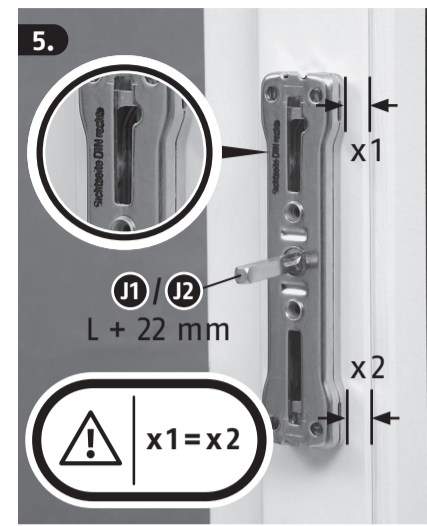
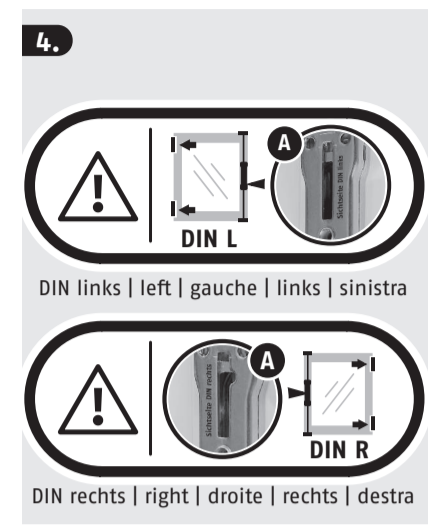
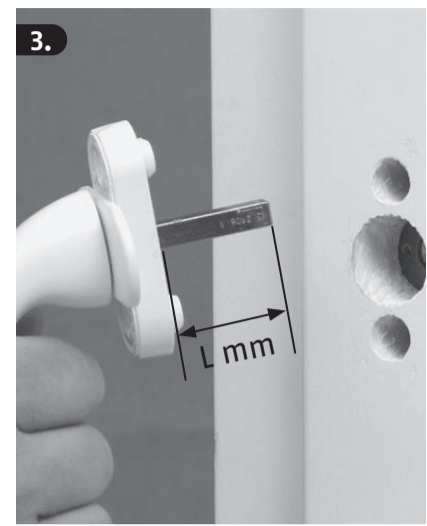
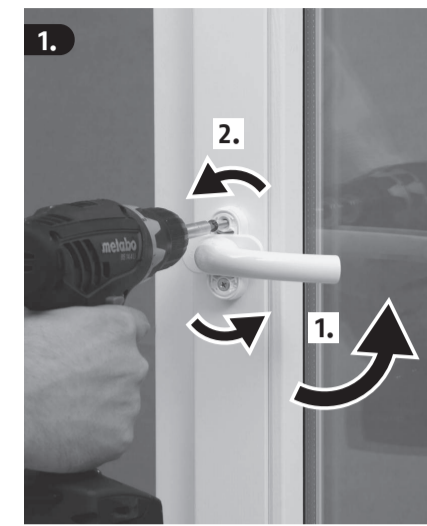
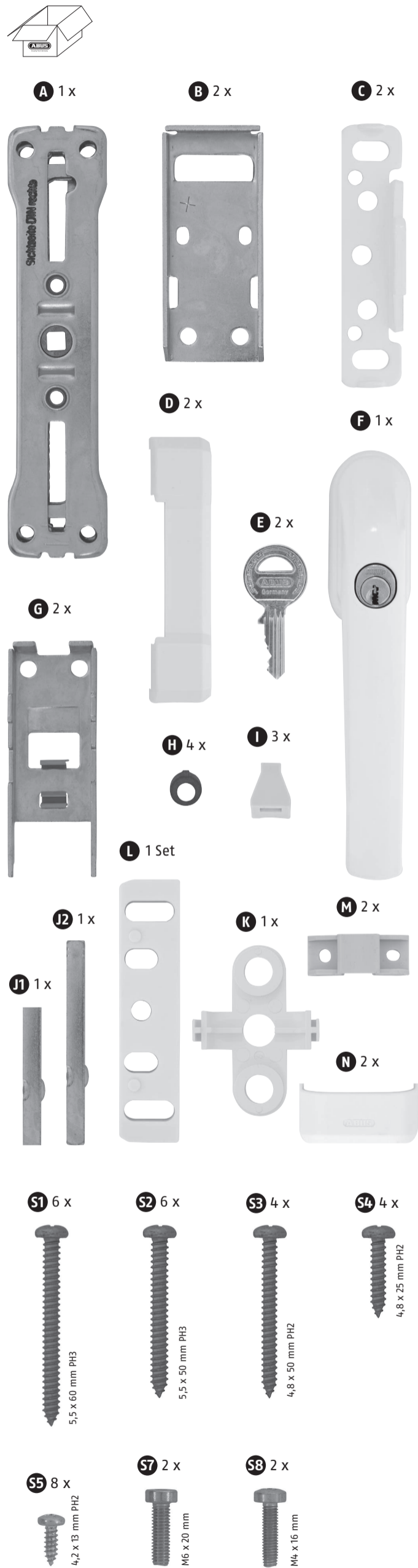

⊗ bündig - gleiche Höhe | ⊗ rincer - même hauteur bloqué | ⊗ spoelen - dezelfde hoogte | ⊗ flush - stessa altezza | ⊗ flush - same height



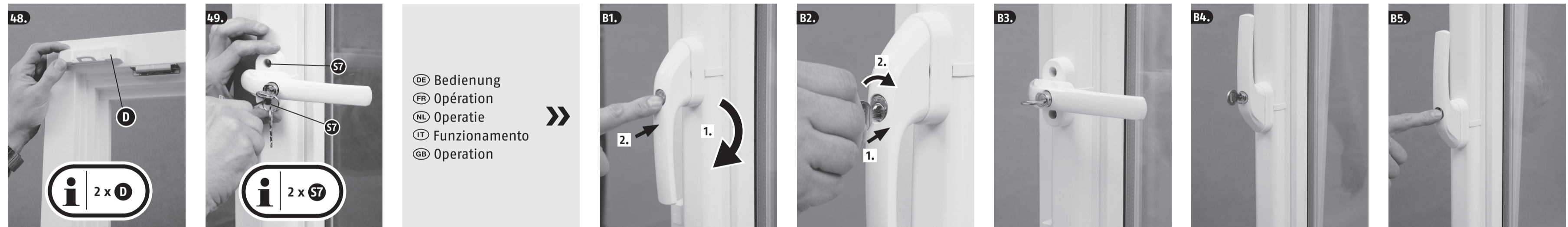
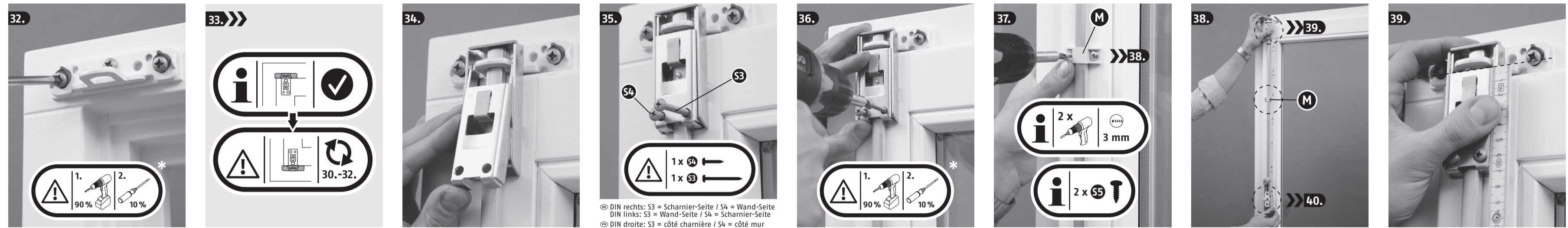
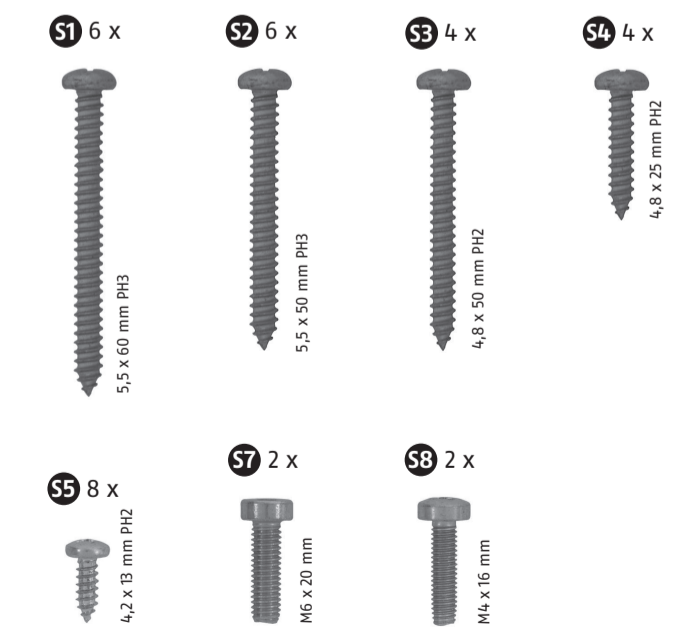
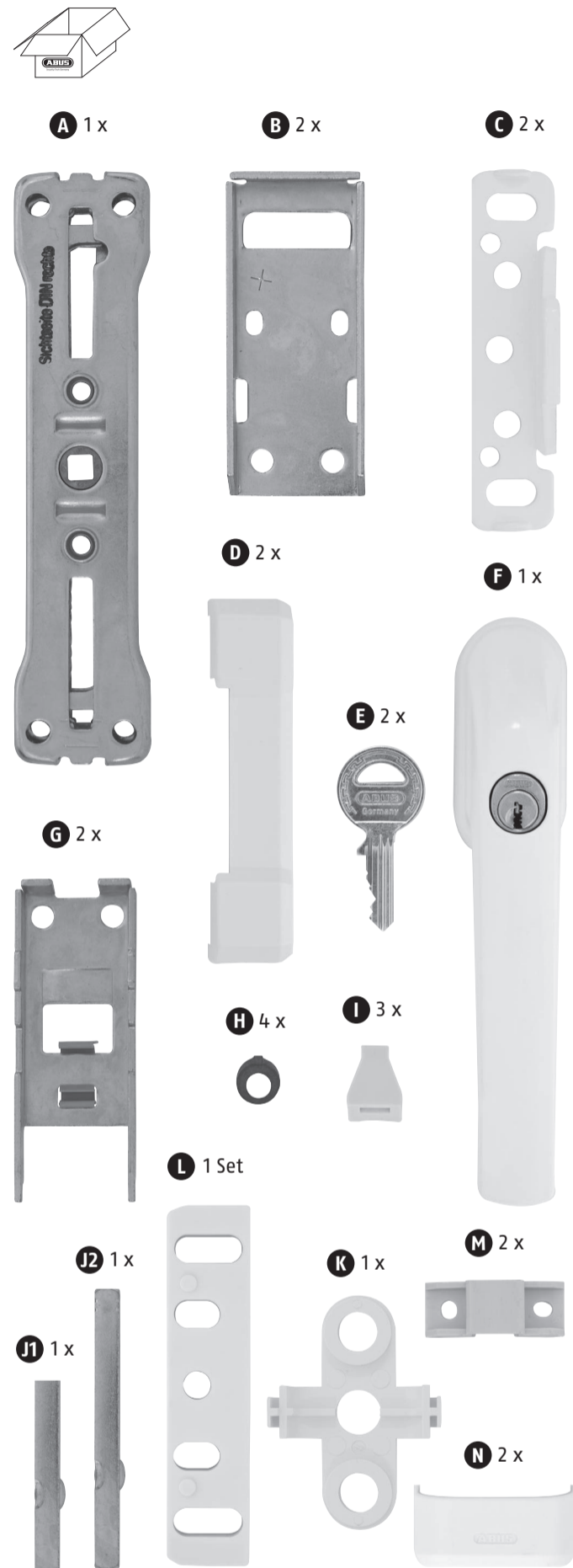

(Tab. 1)

DE	Stangenset	Stangenlänge	Nutzhöhe
GB	Rod set	Length of bars	Usable height
FR	Jeu de barres	Longueurs de barres	Hauteur effective
NL	Stangenset	Langte staaf	Effectieve hoogte
IT	Kit aste	Lunghezza asta	Altezza effettiva
1	75 / 75 cm	80 / 80 cm	
2	75 / 118 cm	80 / 123 cm	
3	118 / 118 cm	123 / 123 cm	
4	150 / 150 cm	155 / 155 cm	

!	90%	10%

**DE Gewährleistung**  
 ABUS Produkte sind mit größter Sorgfalt konzipiert, hergestellt und nach geltenden Vorschriften geprüft. Die Gewährleistung erstreckt sich ausschließlich auf Mängel, die auf Material- oder Herstellungsfehler zurückzuführen sind. Falls nachweislich ein Material- oder Herstellungsfehler vorliegt, wird das Produkt nach Ermessen von ABUS repariert oder ersetzt. Die Gewährleistung endet in diesen Fällen mit dem Ablauf der ursprünglichen Gewährleistungslaufzeit. Weitergehende Ansprüche sind ausdrücklich ausgeschlossen.

ABUS haftet nicht für Mängel und Schäden, die durch äußere Einwirkungen (z.B. Transport, Gewalteinwirkung), unsachgemäße Bedienung, normalen Verschleiß und Nichtbeachtung dieser Anleitung entstanden sind. Bei Geltendmachung eines Gewährleistungsanspruchs ist dem zu beanstandenden Produkt der originale Kaufbeleg mit Kaufdatum und eine kurze schriftliche Fehlerbeschreibung beizufügen.

Technische Änderungen vorbehalten. Für Druckfehler und Irrtümer keine Haftung.

**GB Warranty**  
 ABUS products are designed, manufactured and tested in accordance with applicable regulations with great care. The warranty exclusively covers faults that are caused by material or manufacturing defects. If a material or manufacturing defect can be proven, the product will be repaired or replaced at the discretion of the warrantor. In such cases, the warranty ends with the termination of the original warranty period. Any further claims are expressly excluded.

ABUS assumes no liability for defects or damage that has been caused by external influences (e.g. transport, external forces), improper use, normal wear and tear or non-compliance with this operating and installation instructions document. If a warranty claim is asserted, the product must be returned with the original receipt with date of purchase and a brief written description of the fault.

Subject to technical alterations. No liability for mistakes and printing errors.

**FR Garantie**  
 Les produits ABUS sont conçus, fabriqués et testés avec beaucoup de soin et selon la réglementation applicable. La garantie couvre uniquement les vices résultant de défauts matériels ou de fabrication prouvés, le produit est réparé ou remplacé au gré du donneur de garantie. La garantie se termine, dans de tels cas, à expiration de la durée d'origine de la garantie. Toute revendication au-delà de cette date est explicitement exclue.

ABUS décline toute responsabilité pour des vices et dommages résultant des influences extérieures (p.ex. avaries de transport, emploi de la force), d'une utilisation inappropriée, de l'usure normale ou de la non-observation des présentes instructions. En cas d'une demande dans le cadre de la garantie, l'article réclamé doit être accompagné du justificatif mentionnant la date d'achat et d'une description du défaut.

Nous nous réservons le droit de toutes modifications techniques. Nous n'assumons aucune responsabilité pour des erreurs ou défauts d'impression éventuels.

**NL Garantie**  
 ABUS producten zijn met de grootste zorgvuldigheid ontworpen, geproduceerd en op basis van de geldende voorschriften getest. De garantie heeft uitsluitend betrekking op gebreken die op materiaal- of fabrieksfouten duiden op het moment van verkoop. Bij bewijs van een materiaal- of fabrieksfout wordt de product na beoordeling van de garantiegever gerepareerd of vervangen. De garantie eindigt in dit geval met het afdienen van de oorspronkelijke garantieperiode. Verdergaande aanspraken zijn uitdrukkelijk uitgesloten.

ABUS is niet aansprakelijk voor gebreken en schade die zijn veroorzaakt door inwerkingen van buitenaf (bijvoorbeeld door transport, inwerking van geweld), onjuist gebruik, normale slijtage of het niet in acht nemen van deze handleiding. Bij het indienen van een garantieclaim moet bij de product het originele aankoopbewijs met datum van de aankoop en een korte schriftelijke beschrijving van de fout worden gevoegd.

Technische wijzigingen voorbehouden. Geen aansprakelijkheid voor vergissingen en drukfouten.

**IT Garanzia**  
 I prodotti ABUS sono progettati con la massima cura, costruiti e collaudati in conformità alle direttive vigenti in materia. La garanzia copre esclusivamente gli inconvenienti a difetti di materiale o di fabbricazione. Nel caso in cui sia comprovato un difetto di materiale o di fabbricazione il prodotto verrà riparato o sostituito a discrezione del garante. La garanzia di qualità termina in questi casi alla scadenza del periodo originario di garanzia. Si escludono espressamente ulteriori pretese.

ABUS non è responsabile per difetti o danni causati da fattori esterni (ad esempio trasporto, uso forzato), da un utilizzo non appropriato, dal normale logoramento o dalle mancate osservanze delle presenti istruzioni. Qualora si faccia valere una pretesa di garanzia, allegare al prodotto d'acquisto originale contenente la data d'acquisto, e una breve descrizione scritta del difetto.

Ci si riservano modifiche tecniche. Per errori e refusi di stampa non ci si assume alcuna responsabilità.



\*ABUS 2018  
 ABUS August Bremicker Söhne KG  
 D 58292 Wetter | Germany  
 Tel.: +49 (0) 23 35 63 40  
 www.abus.com | info@abus.de