

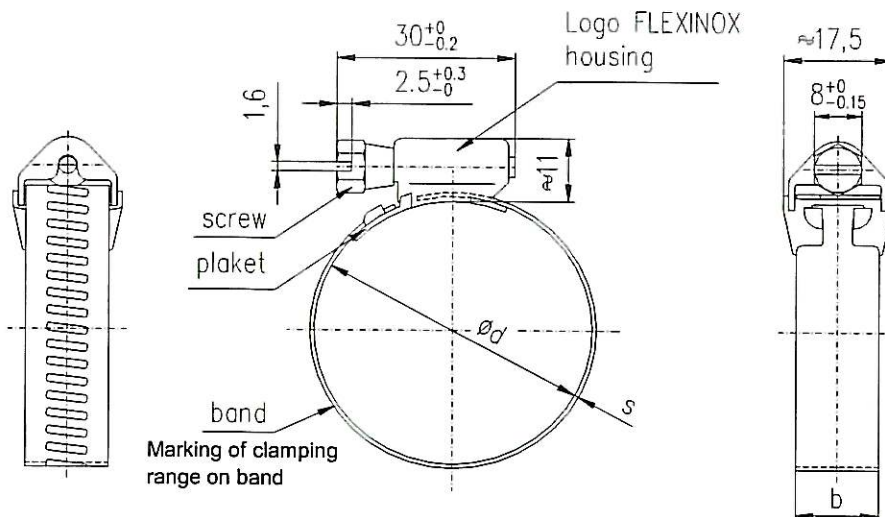

Worm drive hose clamps

FX 13

Dimension, designation:



Dimension in mm:

Type of screw
SW 8 mm with
longitudinal slot,
fine machining

Clamps delivered
separately
- heads and bands

Designation: FX 13 25 - 45 W4

Type Band width Clamping range Type of screw Material code

Table No. 1: Dimension

Clamping range d (mm)	S (mm)	b (mm)	Supplied diameter (mm)
14-22	W1: 0,6 ± 0,03	W1 13 ± 0,3	Clamps delivered separately -heads and bands
18-28			
24-36			
25-45			
32-52			
40-60			
47-67			
62-82			
77-97			
92-112			
107-127			
122-142			
137-157			
152-172			
167-187			
182-202			
197-217			
212-232			
227-247			
242-262			

Surface treatment:
Individual components made from material corresponding to
as for table No.3 :
Band, housing, plaquette and worm screw:
Chrom-nickel steel 1.4301 (AISI304) to DIN EN 10088-2 or equivalent
stainless steel

Corrosion test:
Galvan. components : 160 h test in salt spray SS DIN 50 018.

Table No.2: Torques

Clamping range d (mm)	Mat. code	Static torques	
		max AD (Nm)	max PD (Nm)
for all sizes	W4	6	7

AD : tightening torques
PD : test torques

Further dimension on request

Table No.3: Material

Code	Band	Housing	Plaket	Screw
W4	Chrom-nickel steel 1.4301(AISI304) to DIN EN 10088-2 or equivalent stainless steel			

TL 013 G1

ABA Czech, s.r.o. Havlíckova 28
CZ-693 01 Hustopeče u Brna
Telefon: +420 519 440 311 Telefax: +420 519 411 282
E-mail: info@abaczech.cz www.abaczech.cz

28.02.05