

CULOTTES ET EMBRANCHEMENTS à 45° mâle-femelle

45°

| Réf. | Ø D/d | NF E | Dimensions (mm) | | | | | Cond. |
|------|---------|------|-----------------|-------|-----|------|------|-------|
| | | | h | Z2 | Z3 | L1 | L2 | |
| BF14 | 32 | * | 34 | 41 | 41 | 23 | 23 | C |
| BH14 | 40 | * | 40 | 51 | 51 | 27 | 27 | C |
| BH24 | 40/32 | * | 33 | 46 | 45 | 27 | 23 | |
| BJ14 | 50 | * | 49 | 63 | 63 | 32 | 32 | C |
| BJ24 | 50/40 | * | 40 | 57 | 55 | 32 | 27 | |
| BJ34 | 50/32 | * | 34 | 54 | 50 | 32 | 23 | |
| BL14 | 63 | * | 59,5 | 81 | 81 | 38,5 | 38,5 | C |
| BL24 | 63/50 | | 59,5 | 82 | 81 | 38,5 | 32 | |
| BL34 | 63/40 | | 40 | 70 | 60 | 38,5 | 27 | |
| BL44 | 63/32 | | 45 | 66 | 55 | 38,5 | 23 | |
| BP14 | 75 | * | 69,5 | 95 | 95 | 44,5 | 44,5 | C |
| BP24 | 75/63 | | 69,5 | 101 | 95 | 44,5 | 38,5 | |
| BP34 | 75/50 | | 69,5 | 91 | 95 | 44,5 | 32 | |
| BP44 | 75/40 | | 69,5 | 81,5 | 95 | 44,5 | 27 | |
| BP54 | 75/32 | | 69,5 | 81,5 | 95 | 44,5 | 23 | |
| BR14 | 80 | | 73,5 | 103 | 103 | 47 | 47 | C |
| BR24 | 80/75 | | 73,5 | 105,5 | 103 | 47 | 44,5 | |
| BR34 | 80/63 | | 54 | 100 | 90 | 47 | 38,5 | |
| BR44 | 80/50 | | 60 | 90 | 80 | 47 | 32 | |
| BR54 | 80/40 | | 55 | 90 | 90 | 47 | 27 | |
| BR64 | 80/32 | | 55 | 90 | 85 | 47 | 23 | |
| BS14 | 90 | * | 82 | 113 | 113 | 52 | 52 | C |
| BS24 | 90/80 | | 82 | 118 | 113 | 52 | 47 | |
| BS34 | 90/75 | | 82 | 109 | 113 | 52 | 44,5 | |
| BS44 | 90/63 | | 82 | 115 | 113 | 52 | 38,5 | |
| BS54 | 90/50 | | 50 | 97 | 87 | 52 | 32 | |
| BS64 | 90/40 | | 82 | 95 | 113 | 52 | 27 | |
| BS74 | 90/32 | | 82 | 99 | 113 | 52 | 23 | |
| BT14 | 100 | * | 90 | 126 | 126 | 57 | 57 | C |
| BT24 | 100/90 | | 90 | 125 | 126 | 57 | 52 | |
| BT34 | 100/80 | | 90 | 124 | 126 | 57 | 47 | |
| BT44 | 100/75 | | 90 | 120 | 126 | 57 | 44,5 | |
| BT54 | 100/63 | | 90 | 115 | 126 | 57 | 38,5 | |
| BT64 | 100/50 | * | 65 | 101 | 87 | 57 | 32 | |
| BT74 | 100/40 | | 65 | 95 | 87 | 57 | 27 | |
| BT84 | 100/32 | | 68 | 91 | 87 | 57 | 23 | |
| BV14 | 110 | * | 97 | 138 | 138 | 61 | 61 | C |
| BV24 | 110/100 | | 97 | 140 | 139 | 61 | 57 | |
| BV34 | 110/90 | | 97 | 145 | 138 | 61 | 52 | |
| BV44 | 110/80 | | 97 | 140 | 138 | 61 | 47 | |
| BV54 | 110/75 | * | 71 | 120 | 112 | 61 | 44,5 | |
| BV64 | 110/63 | | 71 | 114 | 112 | 61 | 38,5 | |
| BV74 | 110/50 | | 71 | 107 | 112 | 61 | 32 | |
| BV84 | 110/40 | | 71 | 102 | 112 | 61 | 27 | |
| BV94 | 110/32 | | 97 | 106 | 139 | 61 | 23 | |

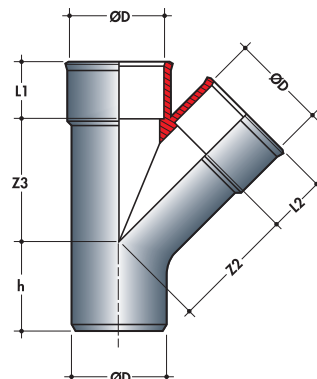

45°

| Réf. | Ø D/d | NF E | Dimensions (mm) | | | | | Cond. | |
|------|---------|------|-----------------|-------|-----|----|------|-------|--|
| | | | h | Z2 | Z3 | L1 | L2 | | |
| BX14 | 125 | * | 102 | 156 | 156 | 61 | 61 | C | |
| BX24 | 125/110 | | 102 | 155 | 156 | 61 | 61 | | |
| BX34 | 125/100 | | 102 | 153 | 156 | 61 | 57 | | |
| BX44 | 125/90 | | 102 | 158 | 156 | 61 | 52 | | |
| BX54 | 125/80 | | 60 | 145 | 140 | 61 | 47 | | |
| BX64 | 125/75 | | 60 | 154 | 140 | 61 | 44,5 | | |
| BX74 | 125/63 | | 60 | 160 | 140 | 61 | 38,5 | | |
| BX84 | 125/50 | | 50 | 127 | 114 | 61 | 32 | | |
| BX94 | 125/40 | | 50 | 118 | 114 | 61 | 27 | | |
| BY14 | 140 | * | 107 | 173 | 173 | 61 | 61 | C | |
| BY24 | 140/125 | | 94 | 169 | 165 | 61 | 61 | | |
| BY34 | 140/110 | | 82 | 162 | 157 | 61 | 61 | | |
| BY44 | 140/100 | | 75 | 157 | 149 | 61 | 57 | | |
| BZ14 | 160 | * | 114 | 197 | 197 | 61 | 61 | C | |
| BZ24 | 160/140 | | 120 | 220 | 210 | 61 | 61 | | |
| BZ34 | 160/125 | | 85 | 183 | 176 | 61 | 61 | | |
| BZ44 | 160/110 | | 74 | 174 | 164 | 61 | 61 | | |
| BZ54 | 160/100 | | 68 | 169 | 157 | 61 | 57 | | |
| BB14 | 200 | | 127 | 247 | 247 | 61 | 61 | C | |
| BB24 | 200/160 | | 99 | 228 | 220 | 61 | 61 | | |
| BB34 | 200/140 | | 115 | 235,5 | 220 | 61 | 53,5 | | |
| BB44 | 200/125 | | 74 | 210 | 195 | 61 | 61 | | |
| BB54 | 200/110 | | 63 | 203 | 164 | 61 | 61 | | |
| BB64 | 200/100 | | 63 | 198 | 177 | 61 | 57 | | |
| BD14 | 250 | | 120 | 311 | 311 | 61 | 61 | | |
| BE14 | 315 | | Nous consulter | | | | | | |