

# Cable Kit Tram' 10w/ml : Schémas de pose – Coupe – spécimen plan de pose

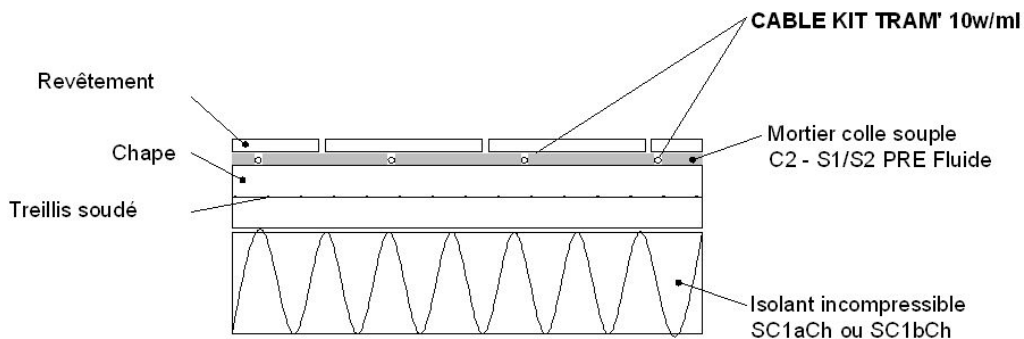

**Cable Kit Tram 10w/ml**  
Pas de 18 cm

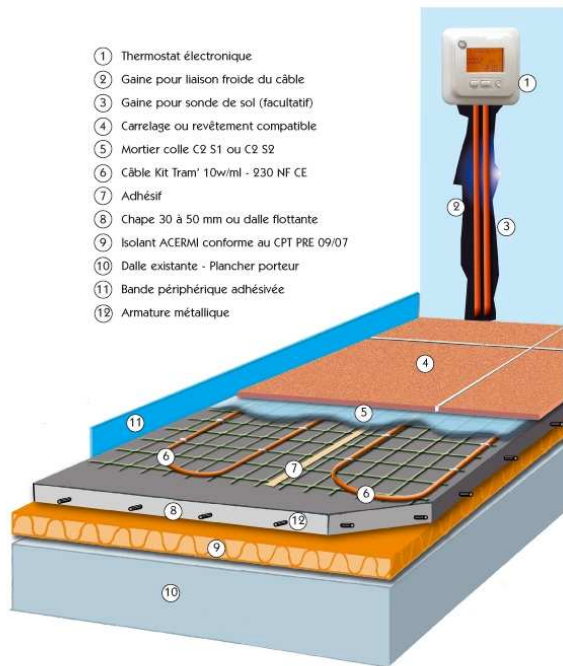