

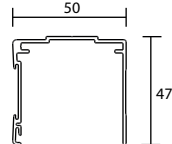









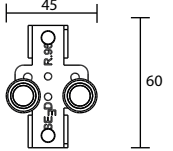

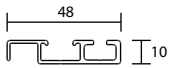
PROFIL MONO-RAIL HAUT  		GUIDE HAUT 96  	
PROFIL MONO-RAIL BAS  		FREIN AMORTISSEUR+EQUERRE  	
CAPOT MONO-RAIL HAUT  		EQUERRE FIXATION MURALE  	
CAPOT MONO-RAIL BAS  		JOINT DE BUTEE  	

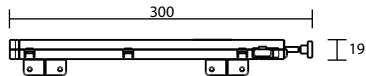
N°	Désignation
1	Profil Mono-Rail Haut
2	Profil Mono-Rail Bas
3	Capot Mono-Rail Haut <i>*sur demande</i>
4	Capot Mono-Rail Bas <i>*sur demande</i>
5	Frein Amortisseur+Equerre
6	Equerre Fixation Murale + Vis
7	Joint de Butée
8	Guide Haut 96 <i>*sans frein amortisseur</i>

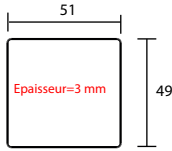

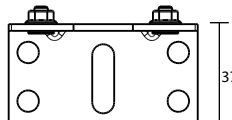
Différentes configurations vue de dessus

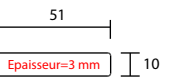
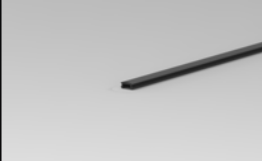
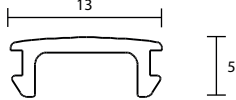
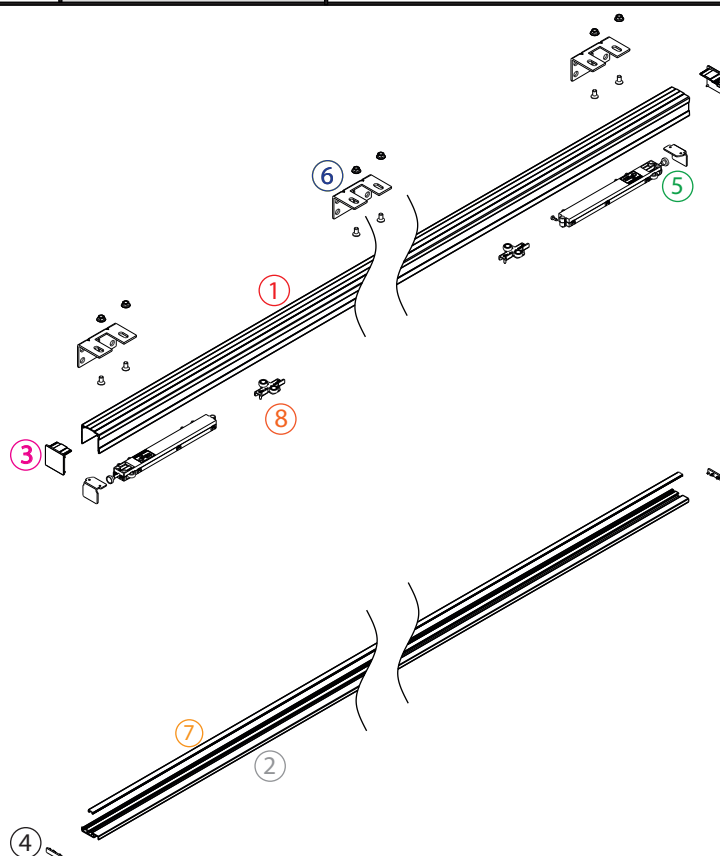
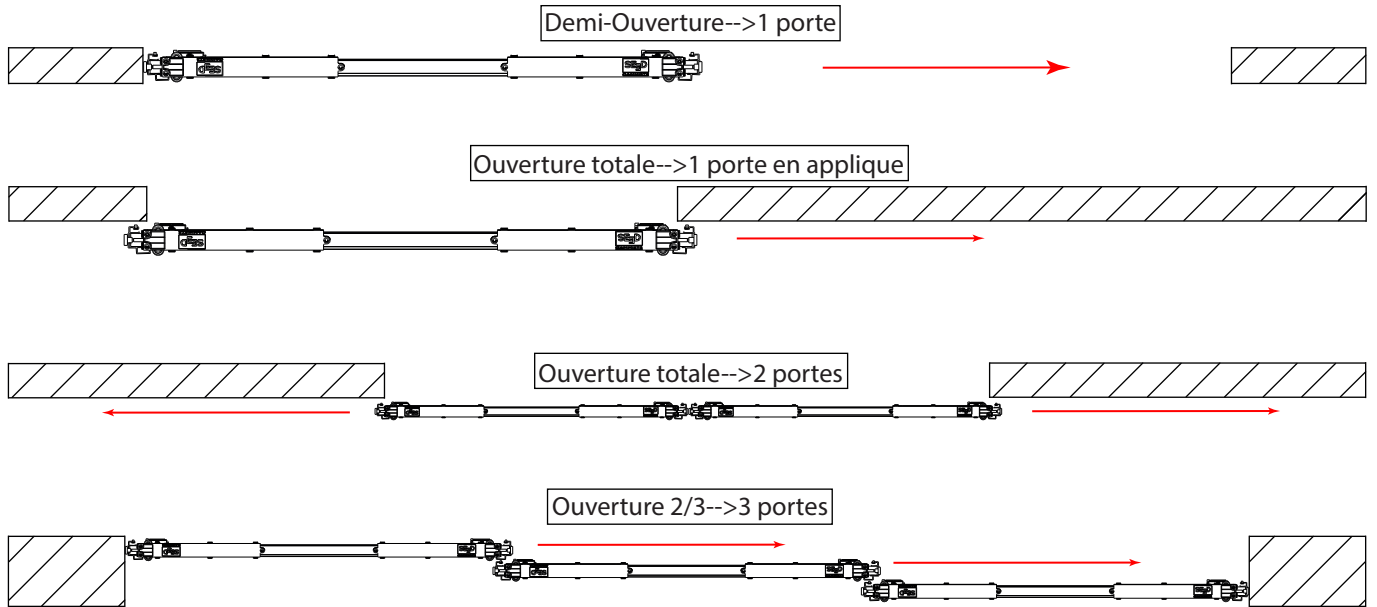

Différentes configurations vue de côté

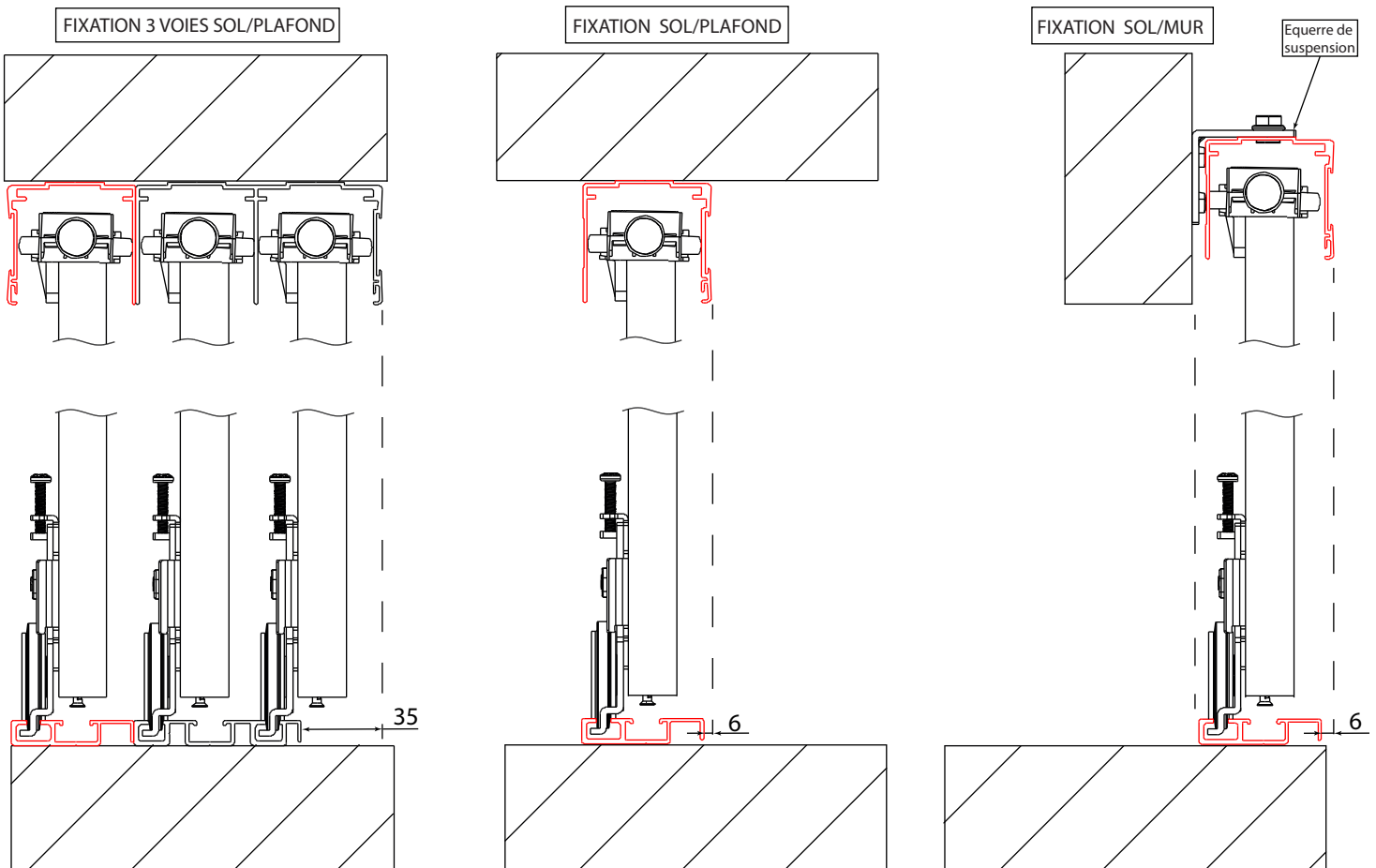

Mise en place du joint cache vis

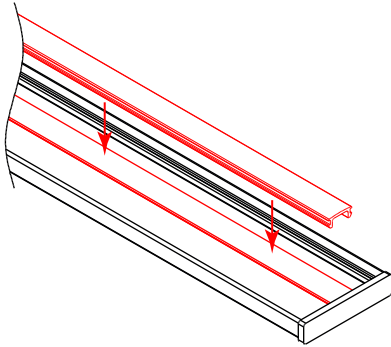

Mise en place du capot mono-rail haut

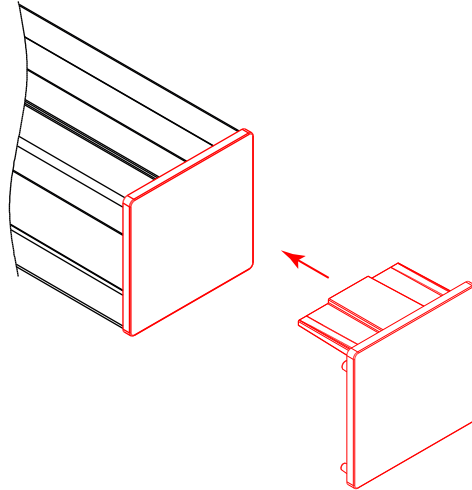

Mise en place du capot mono-rail bas

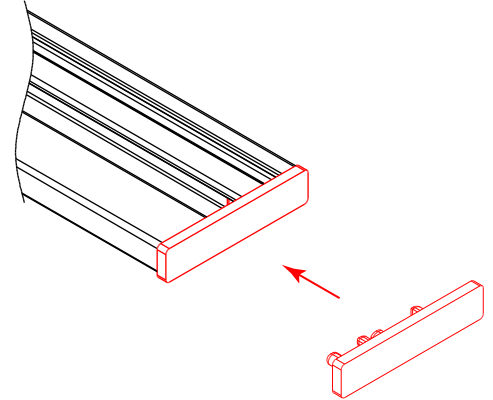

Mise en place du mono-rail haut avec équerre de suspension

